



• Straight Stairlift



• Curved Stairlift



• Accessibility Platform Lift

# ACCESSIBILITY MOBILITY SOLUTIONS

Stair Lifts & Vertical Platform Lifts

Engke Mobility Group Limited

# Curved Stair Lift

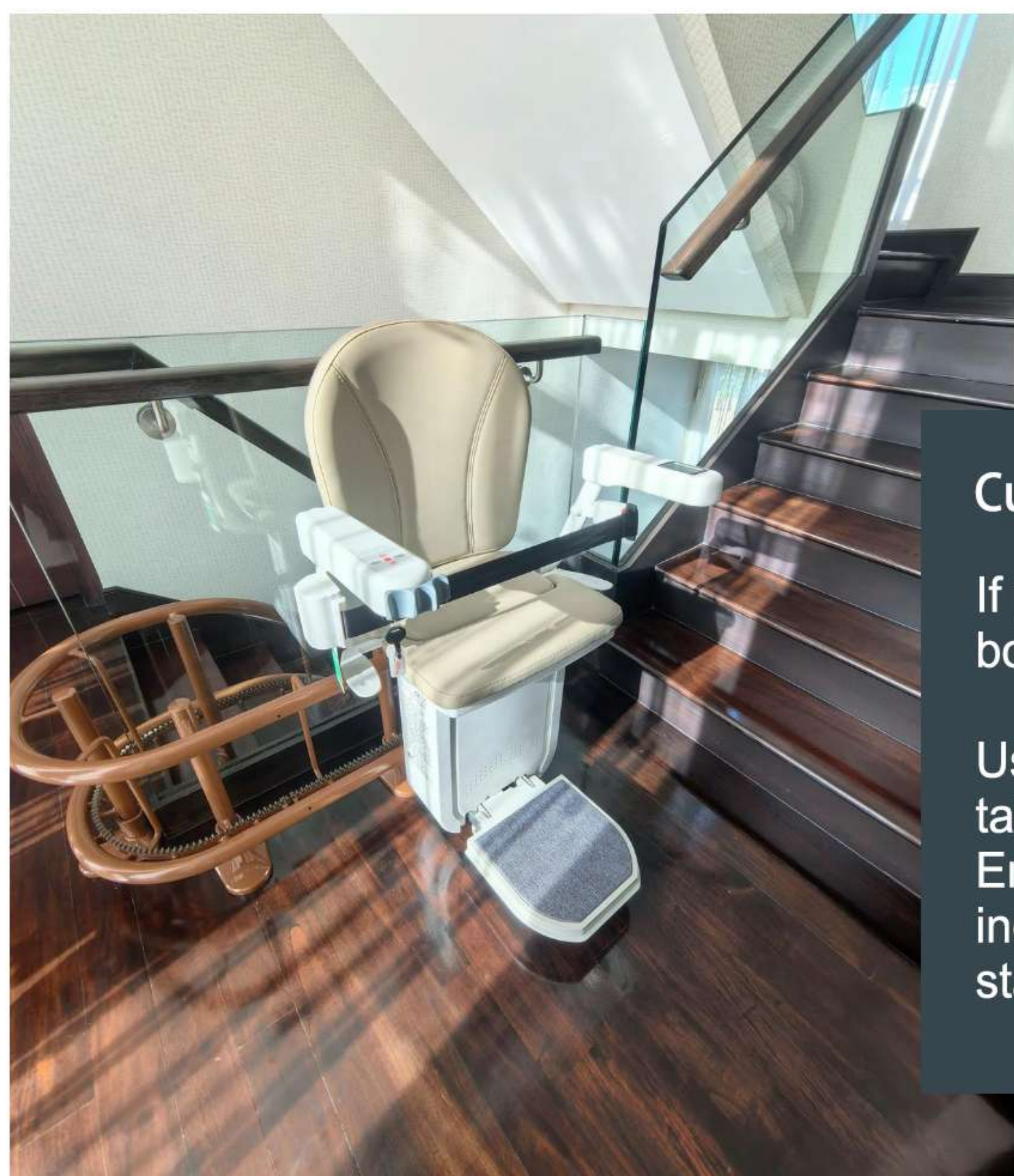

## Curved Stair Lift

If your staircase has turns, intermediate landings or limited space at the top or bottom, you may require a Curved Stairlift.

Using a unique modular system, accurate measurements enable Engke to tailor-make a stairlift rail which closely follows the contour of your staircase. Engke stairlifts are designed to suit your individual home and lifestyle and include space-saving features such as 180 parking bends at the top of the staircase.

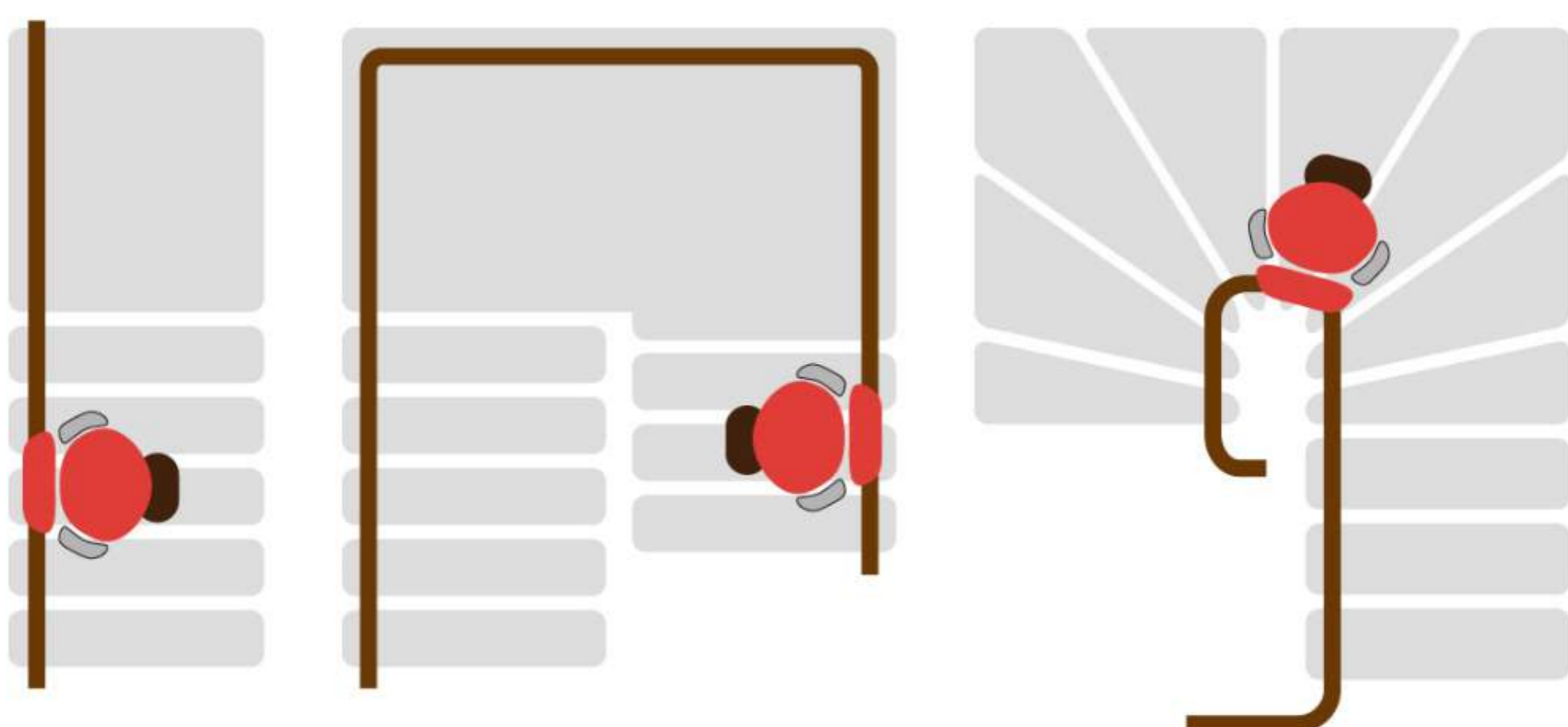

With our advanced technology, fully customized handrail installation becomes possible. Our unique system allows us to fit stairlifts even on narrow, steep spiral staircases or stairways with complex shapes.

We bend a single-piece rail to match the exact contour of your staircase and secure it directly onto the stair treads — ensuring a perfect fit while avoiding any damage to your walls.

**1) ERGONOMIALLY DESIGNED SEAT**

Luxuriously upholstered, ensuring a comfortable, smooth ride. Various colour options are available.

**2) MANUAL OR POWERED SWIVEL OPTIONS**

Simple operation with either option safely enabling the user to easily turn the seat on arrival.

**3) MANUAL FOOTREST LEVEL**

No awkward bending to lower and raise the footrest. A powered option is available.

**4) EASY TO USE ERGONOMIC JOYSTICK**

Effortless directional control, even for those with limited dexterity.

**5) ELECTRONIC KEYSWITCH**

Complete security from any unwanted users.

**6) SEATBELT FOR EXTRA SAFETY**

Easy-to-use seatbelt, offering the user added safety and comfort.

**7) SENSITIVE SAFETY EDGES**

Enabling the stairlift to stop safely, should something obstruct it. Safety is always our priority.

**8) DC BATTERY POWERED**

Works even during a powercut. It also charges automatically so the chair is always ready to use.

**9) HEAVY DUTY OPTION**

The stairlift comfortably accommodates users up to 190kg.

**10) L.E.D DIAGNOSTIC DISPLAY**

Should any problems arise, these are easily solved by checking the diagnostic display.



### Standard Staircase Illustration

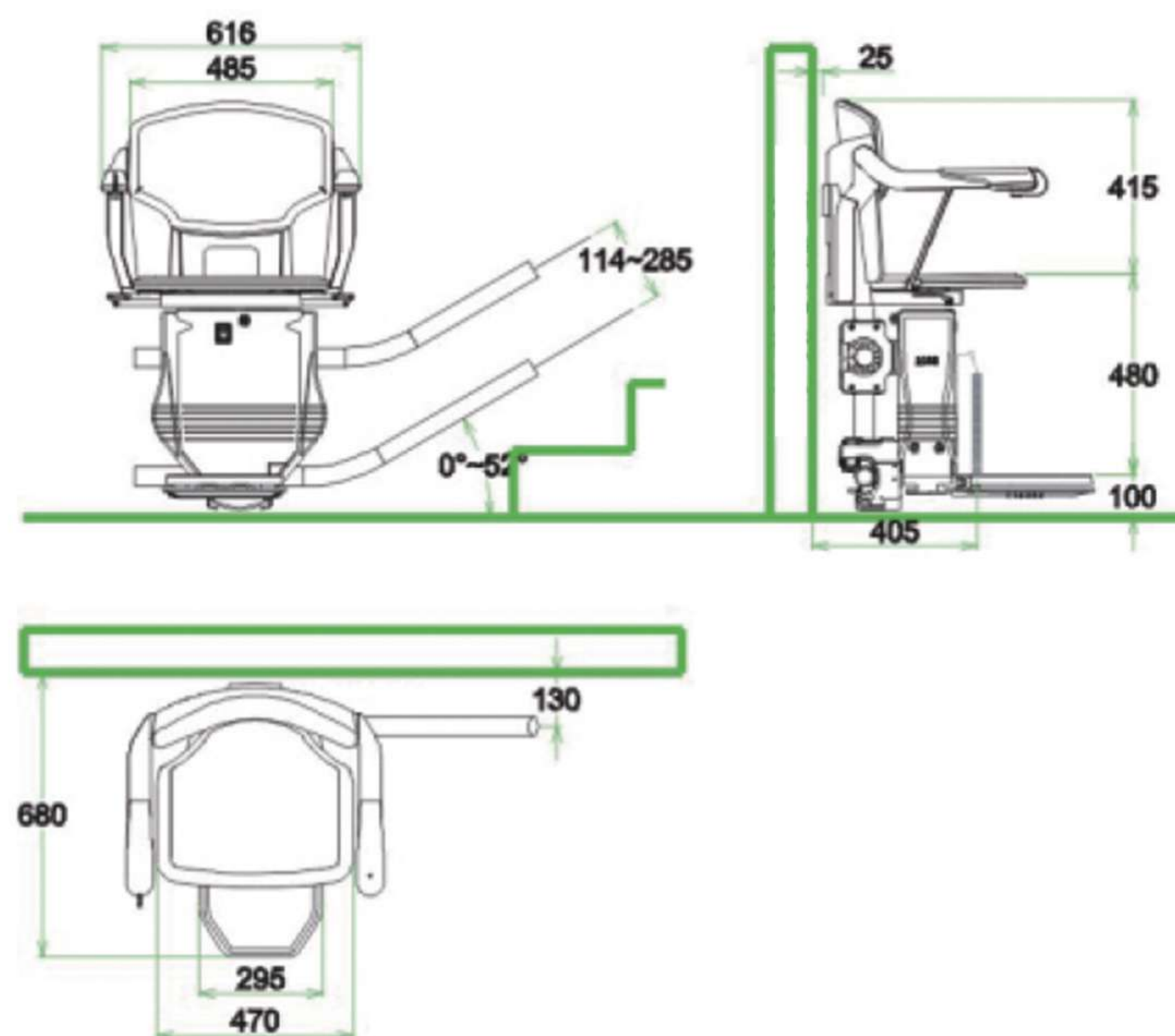

### Curved Stair Lift Installation Illustration

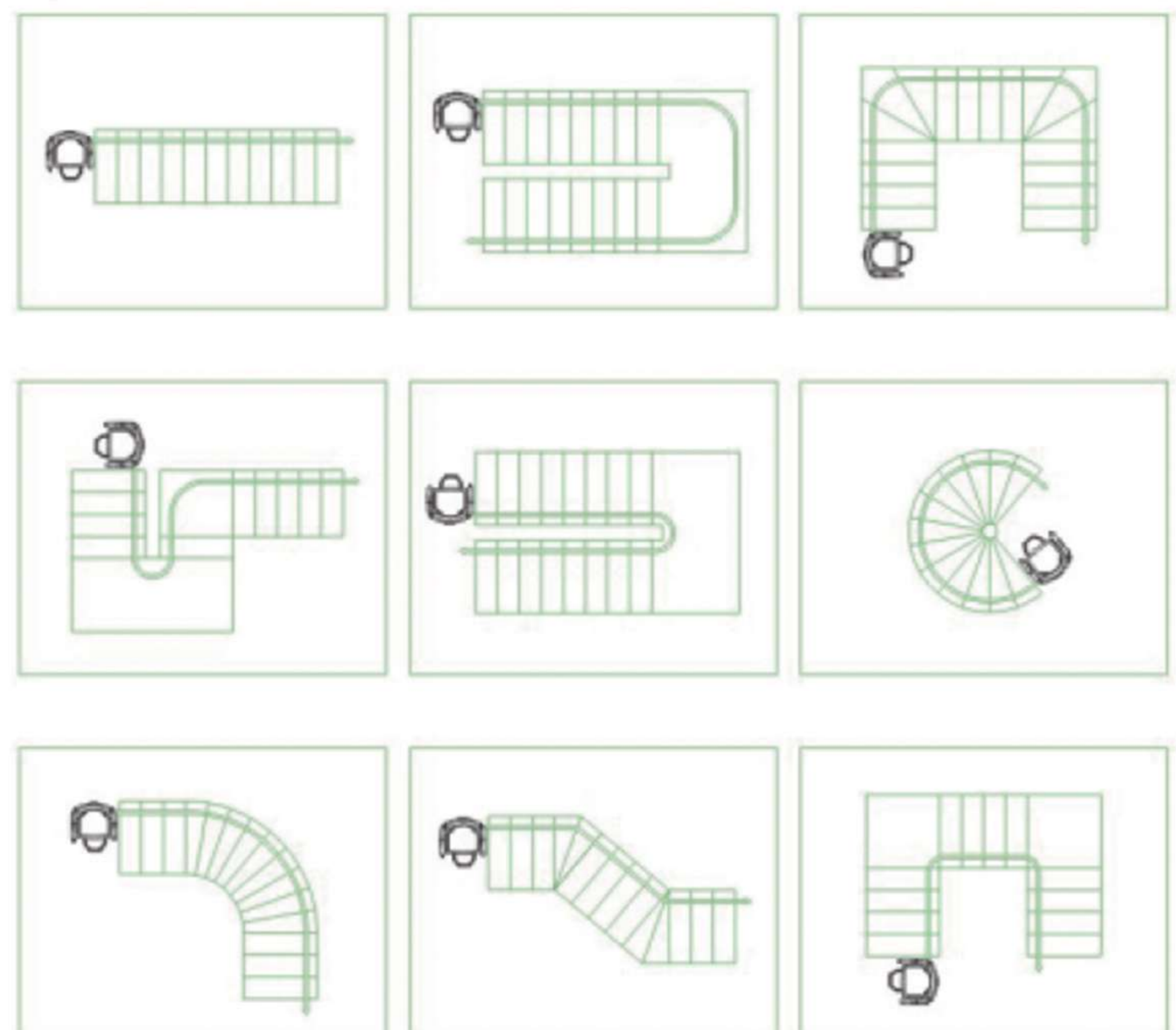



# Straight Stair Lift

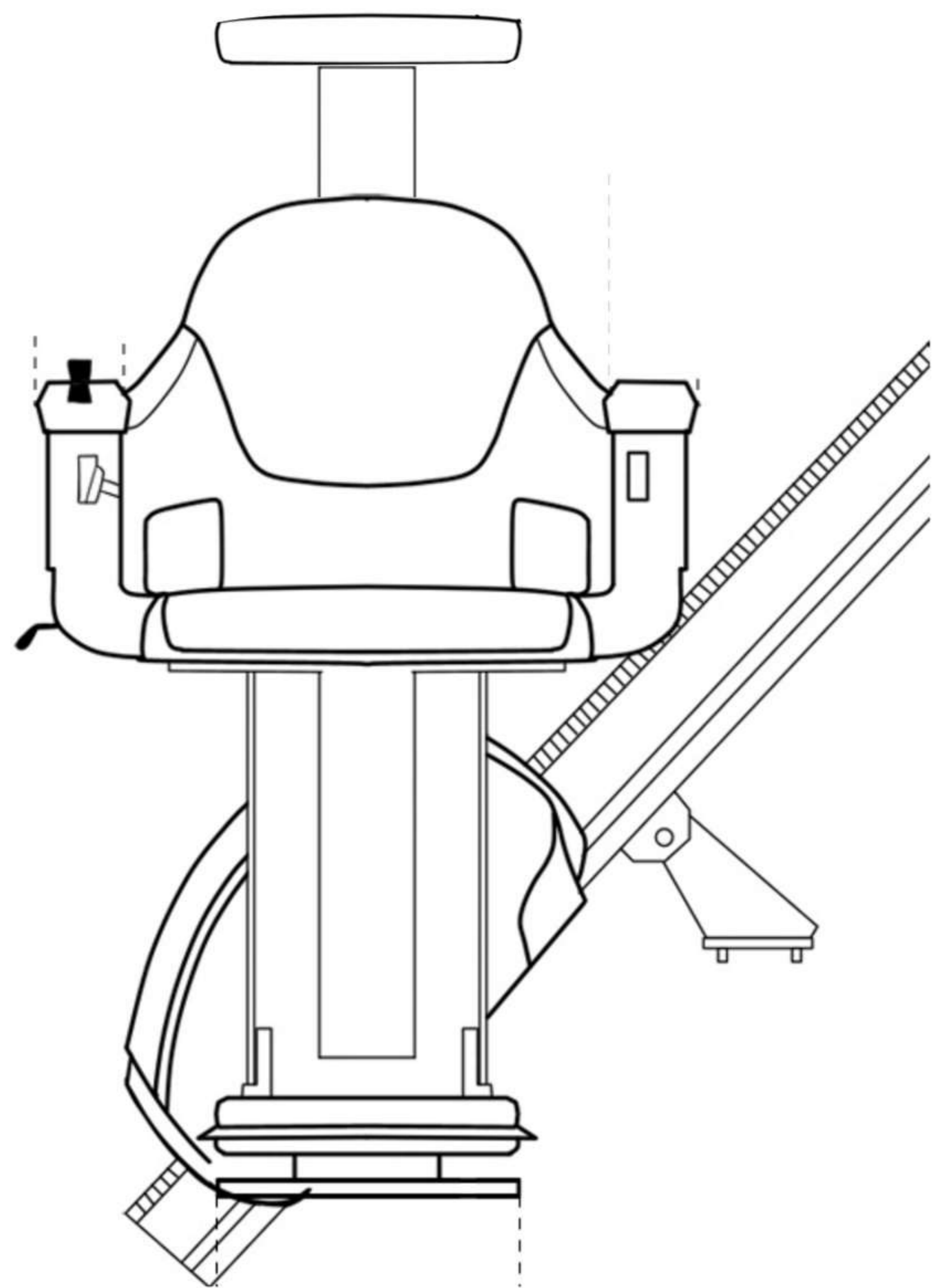
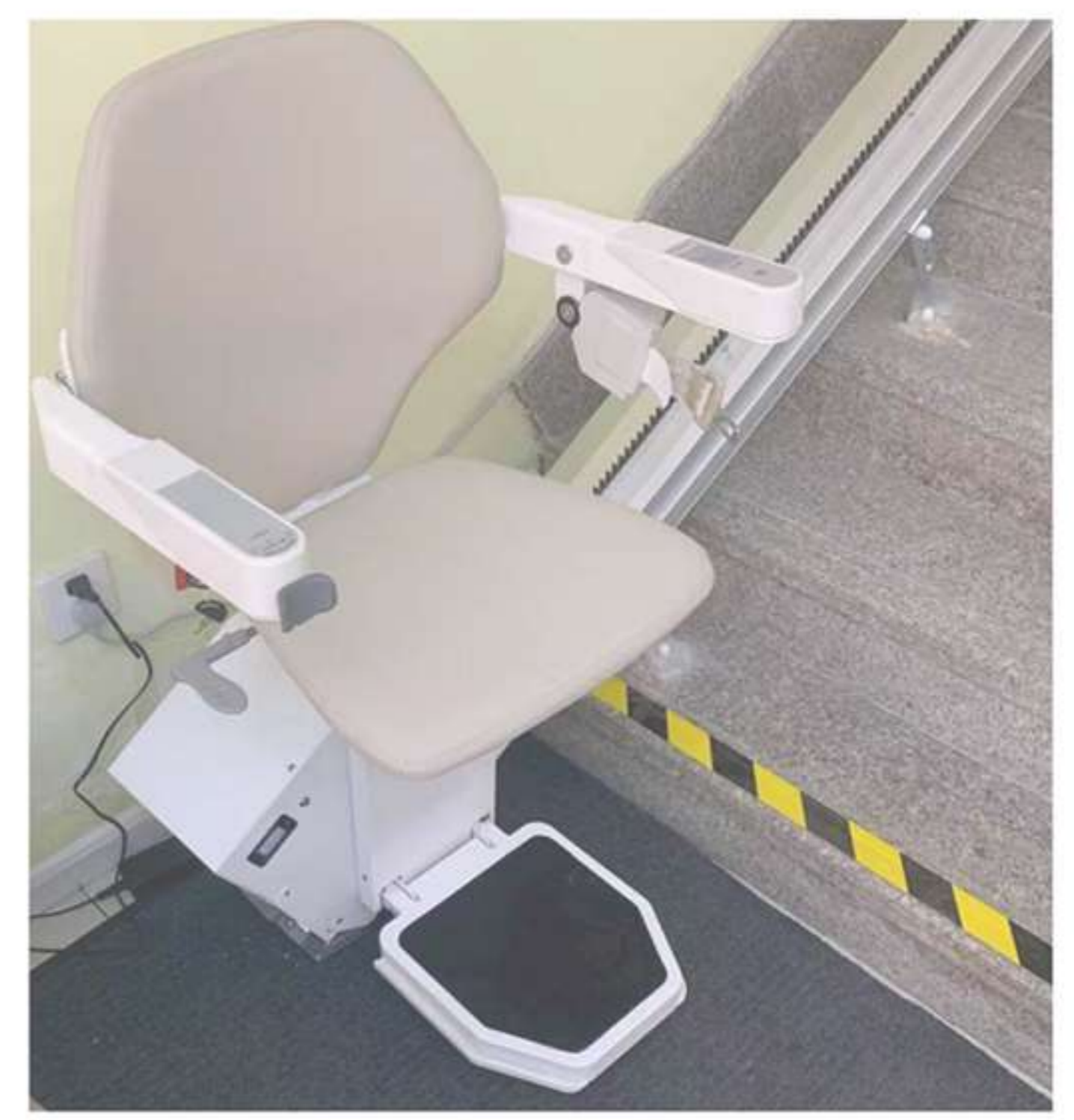
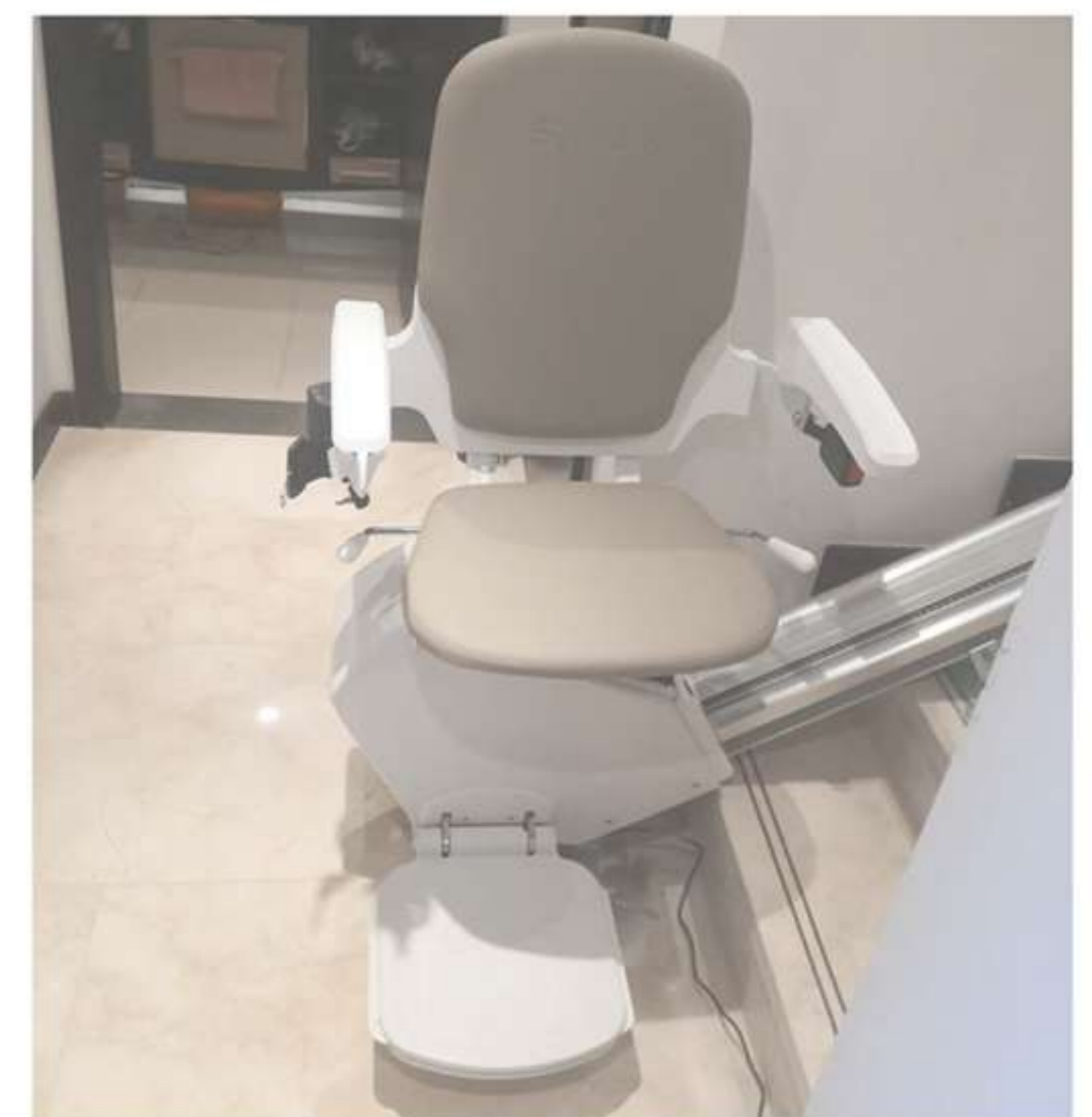
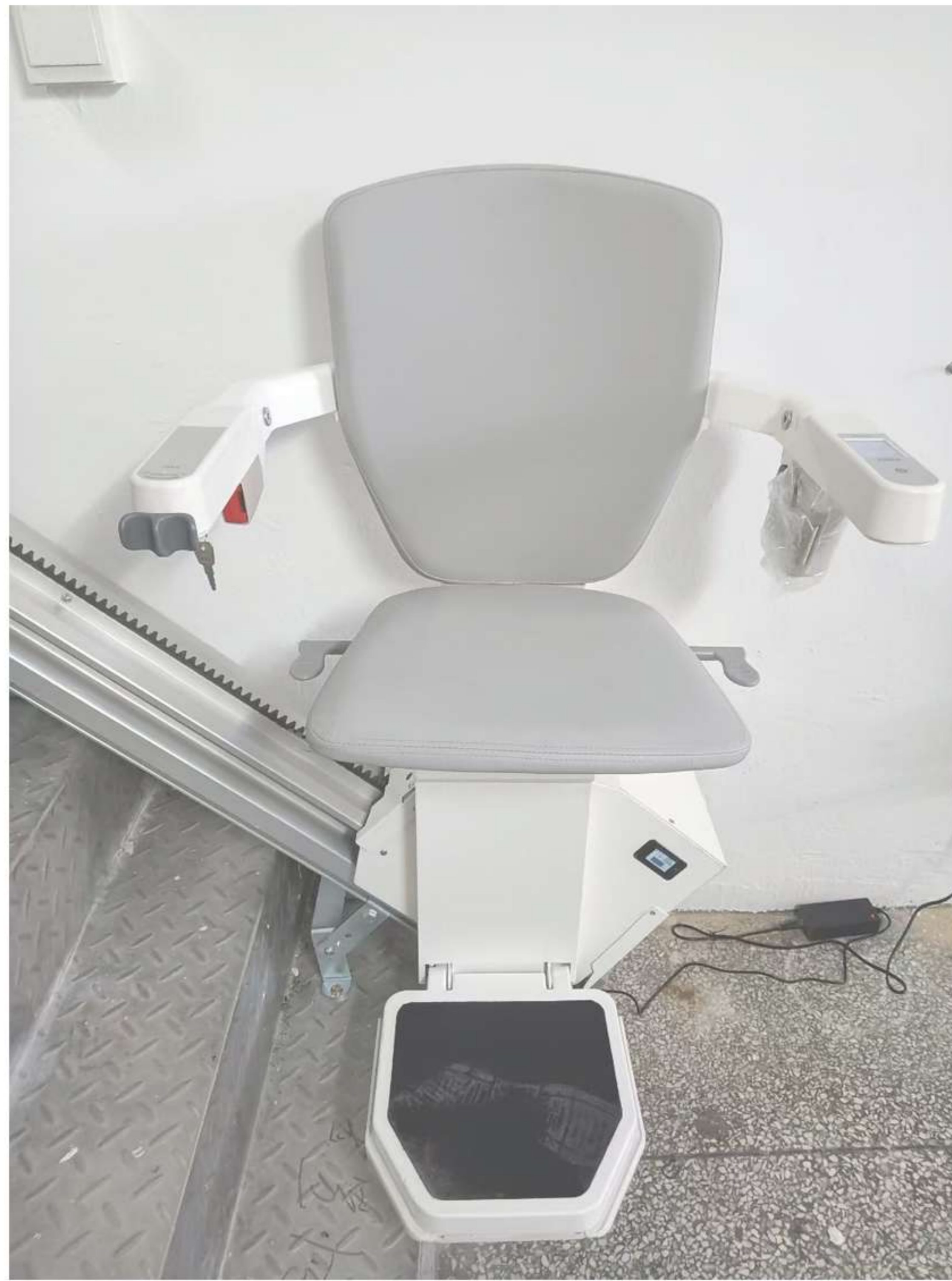

## Straight Stairlift

Practical & Reliable Mobility for Straight Staircases

The ENGKE straight stairlift is designed for homes with straight staircases and no intermediate turns or landings. It offers a simple, safe, and cost-effective solution for elderly users or people with limited mobility to move comfortably between floors.

With a compact rail design and stable drive system, the lift can be installed without major structural changes, making it ideal for both private homes and low-rise residential buildings.

# STAIRLIFT INSTALLATION CASES

Over the years many people have asked how to measure their stairs, so we have produced this simple guide to show you how. This step-by-step guide is for straight staircases only. If your staircase is curved and has bends and turns, it is best to request the help of a surveyor, which we can also help you with.

All you need is a 5m tape measure and a notebook to write down the measurements. Please also send us some photos from a camera or phone so that we can view the staircase in full. Try to include any power sockets near the top or bottom of the stairs and also show the front door in relation to the stairs so we can determine the level of access for installing the stairlift.

## Step One Installation side

Stand at the bottom of the stairs and look up the staircase. This will determine if the stairlift should be installed on the left or right side. With safety in mind the best side for a stairlift is always on the outside wall side. If the staircase has walls on both sides or is situated in the middle of the house, then determine which side would be most practical for the user of the stairlift from the bottom of your staircase.

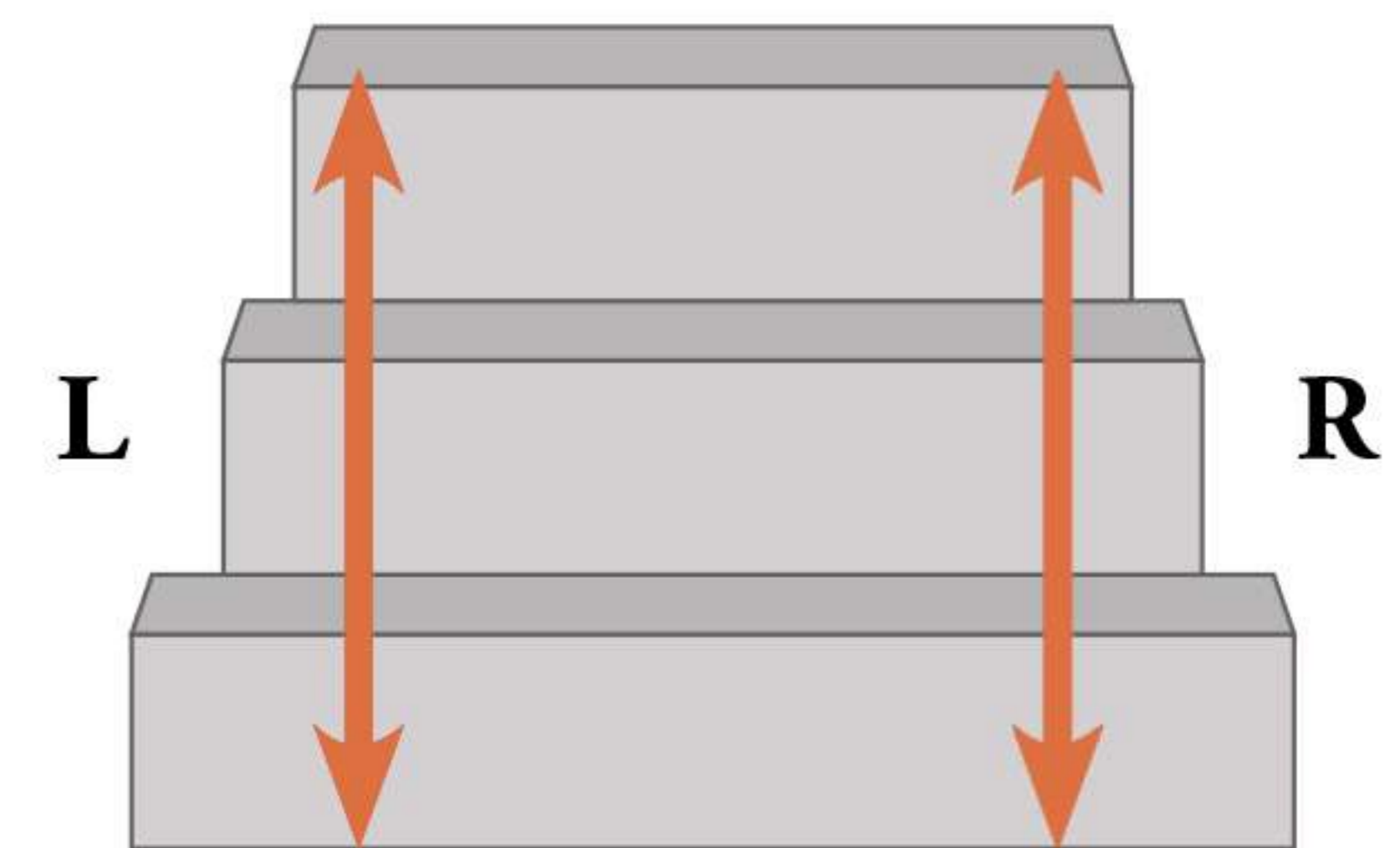

## Step Two-Staircase Length

Stand at the top of the staircase and measure from the top stair tread (A) and run your tape measure down the staircase. The tape measure should touch every edge of every stair tread and the tip of the tape measure should be extended right down to the bottom floor area. This is your floor to top nose measurement.

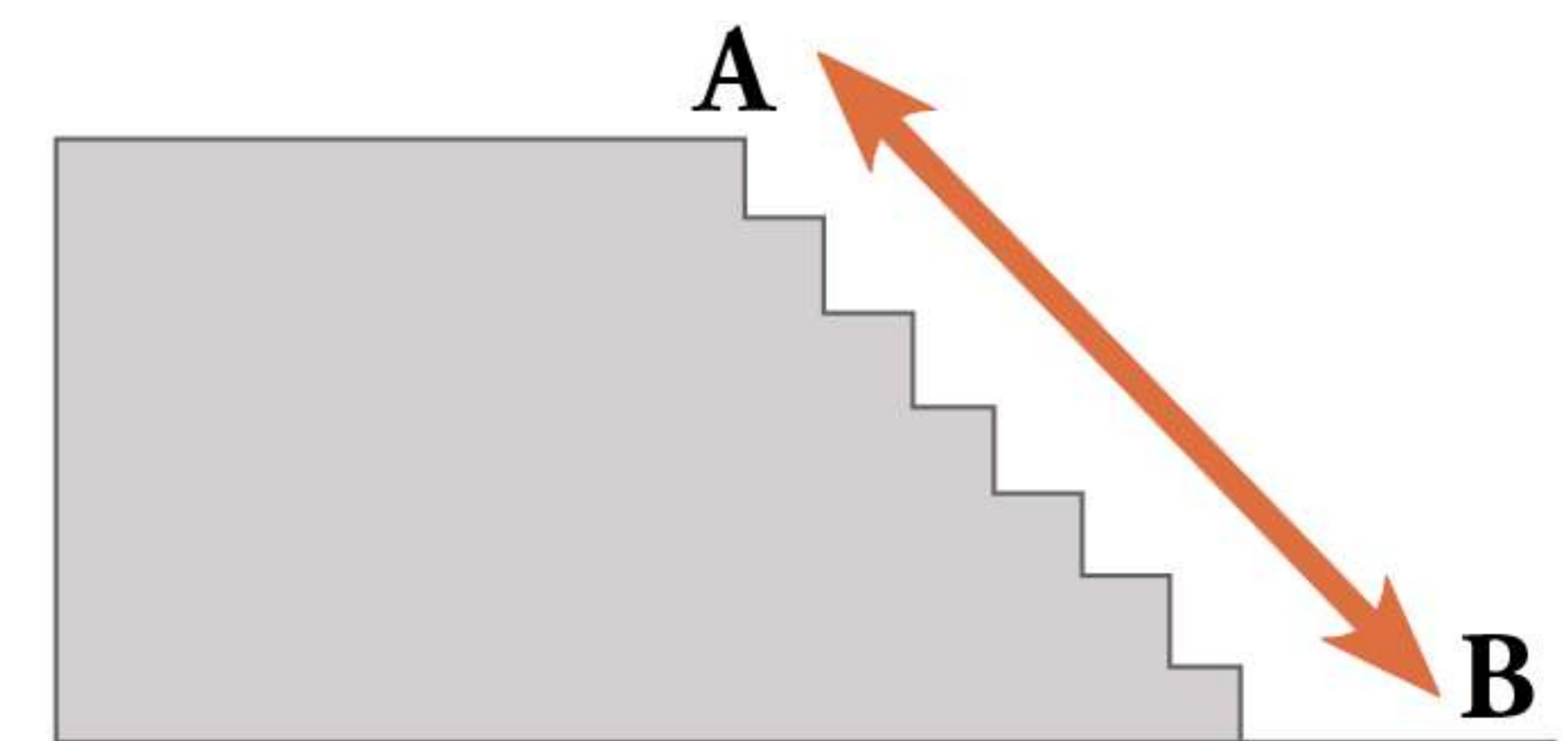

## Step Three-Staircase Width

Measure the width of the staircase from the most narrowest point along them (C to D) making sure you measure from the skirting board and not the wall. Please take into account all newel posts and hazards that might cause a problem during travel.

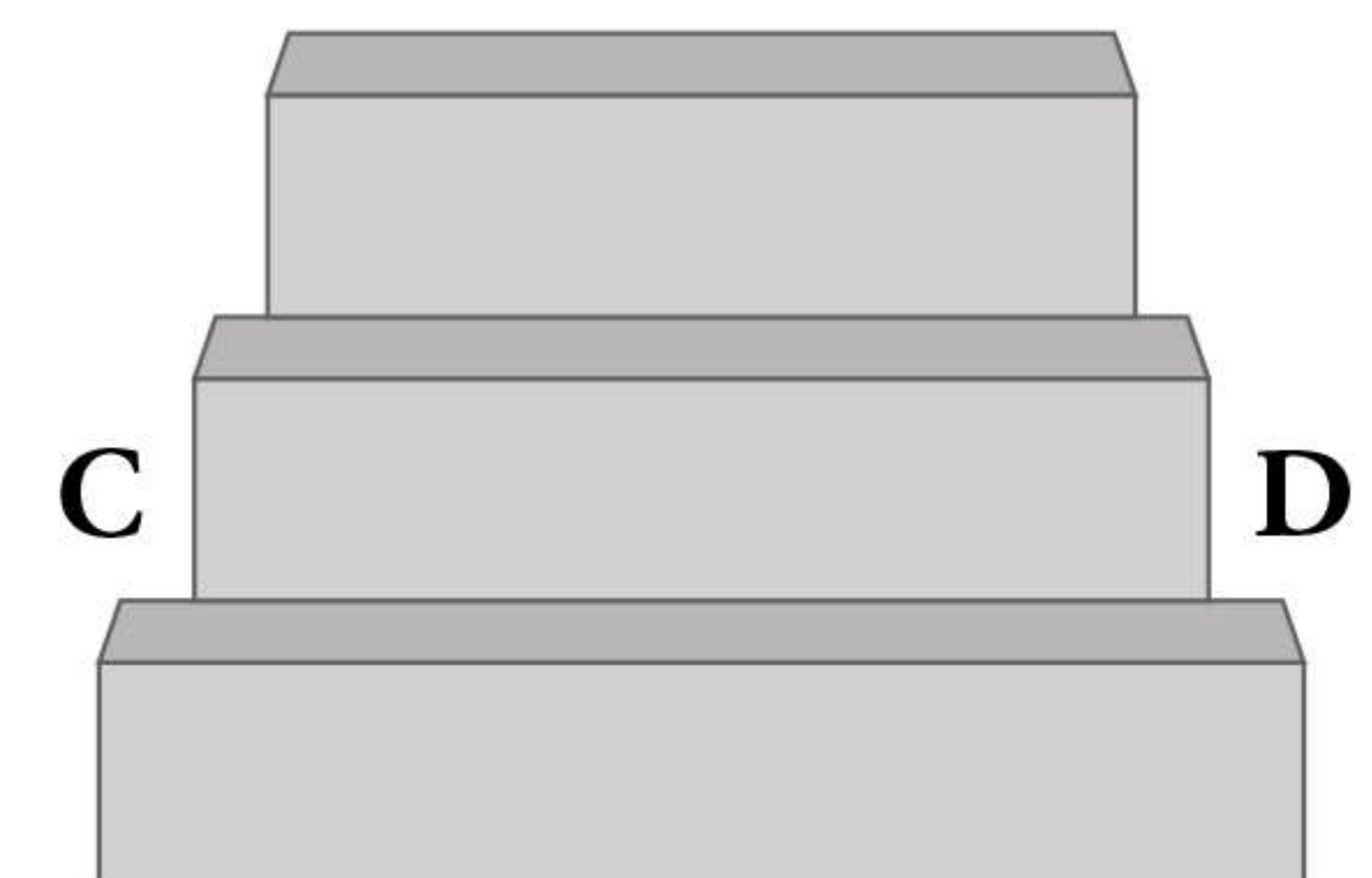

## Step Four-Bottom Clearing Measurement

Measure from the riser of the bottom stair tread (E) to the nearest obstacle (F). This could be a nearby door opening, radiator, wall or cupboard. A minimum distance of 18" to 20" (450mm - 500mm) is needed for the stairlift to be parked for getting on and off safely. If the space is limited you may require a hinge rail system.

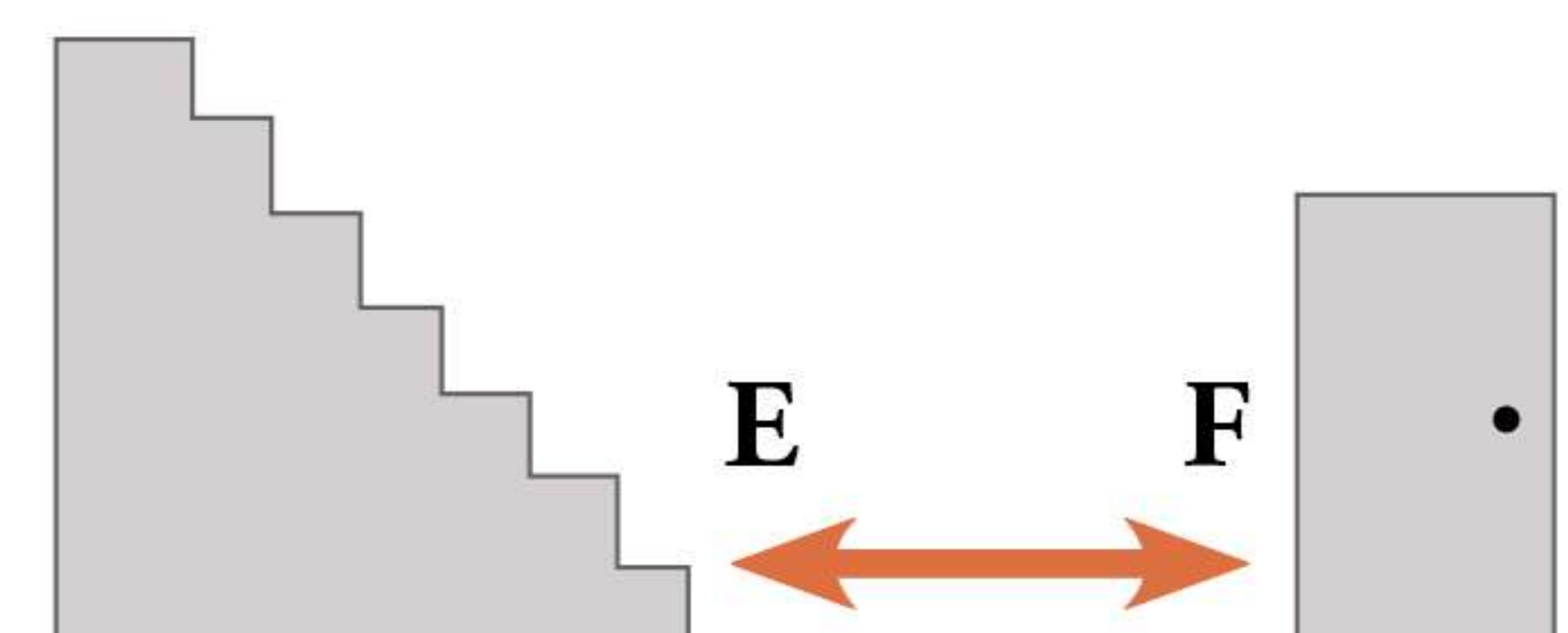

## Step Five-Nose to Nose Measurement

Measure from the same point on the nose of tread 2 to exactly the same point on the nose of tread 3 in a straight line. This is normally around 300mm but can be plus or minus 25mm depending on the age and design of the staircase. This enables us to double check your measurements.

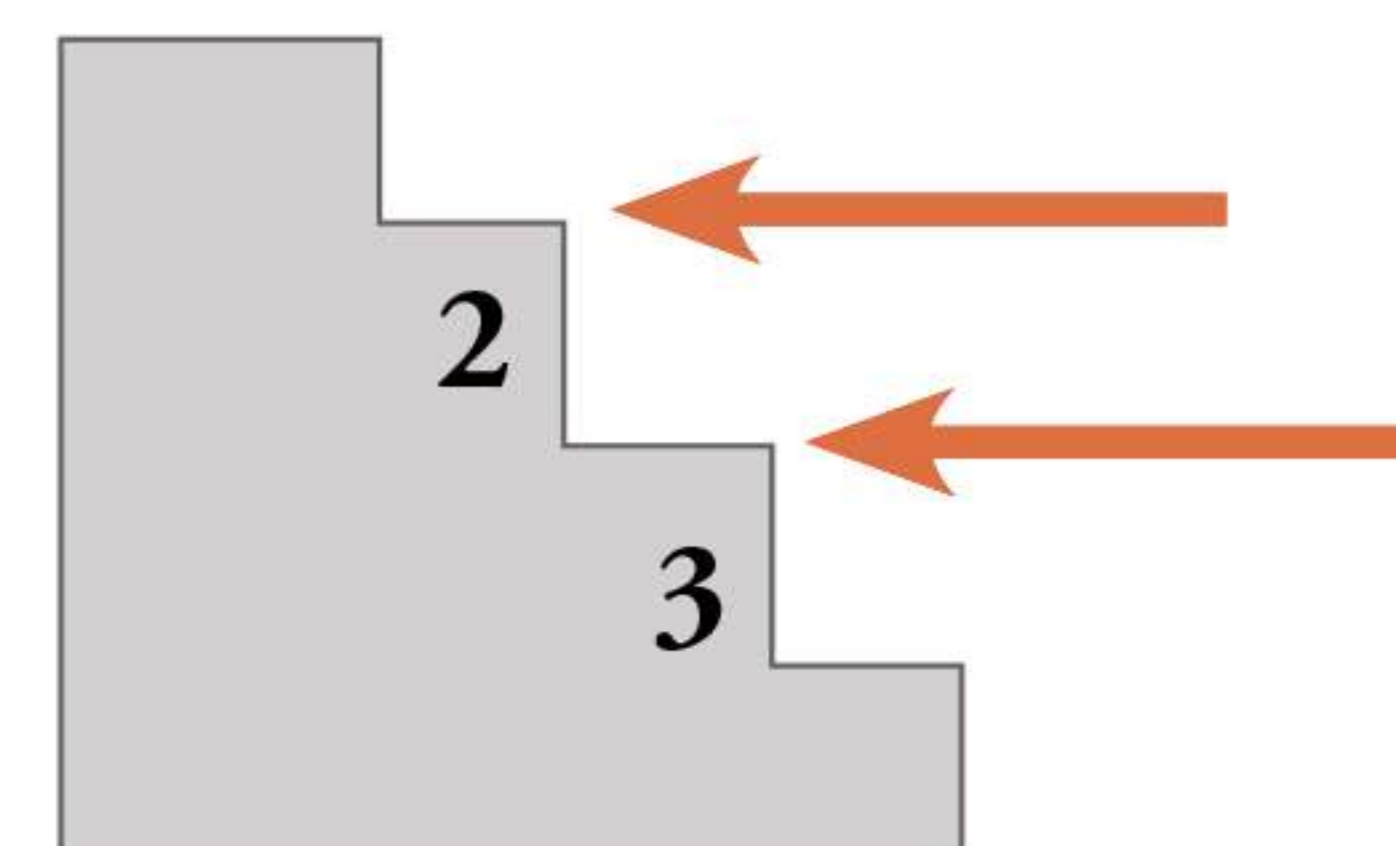

# INSTALLATION EXAMPLES

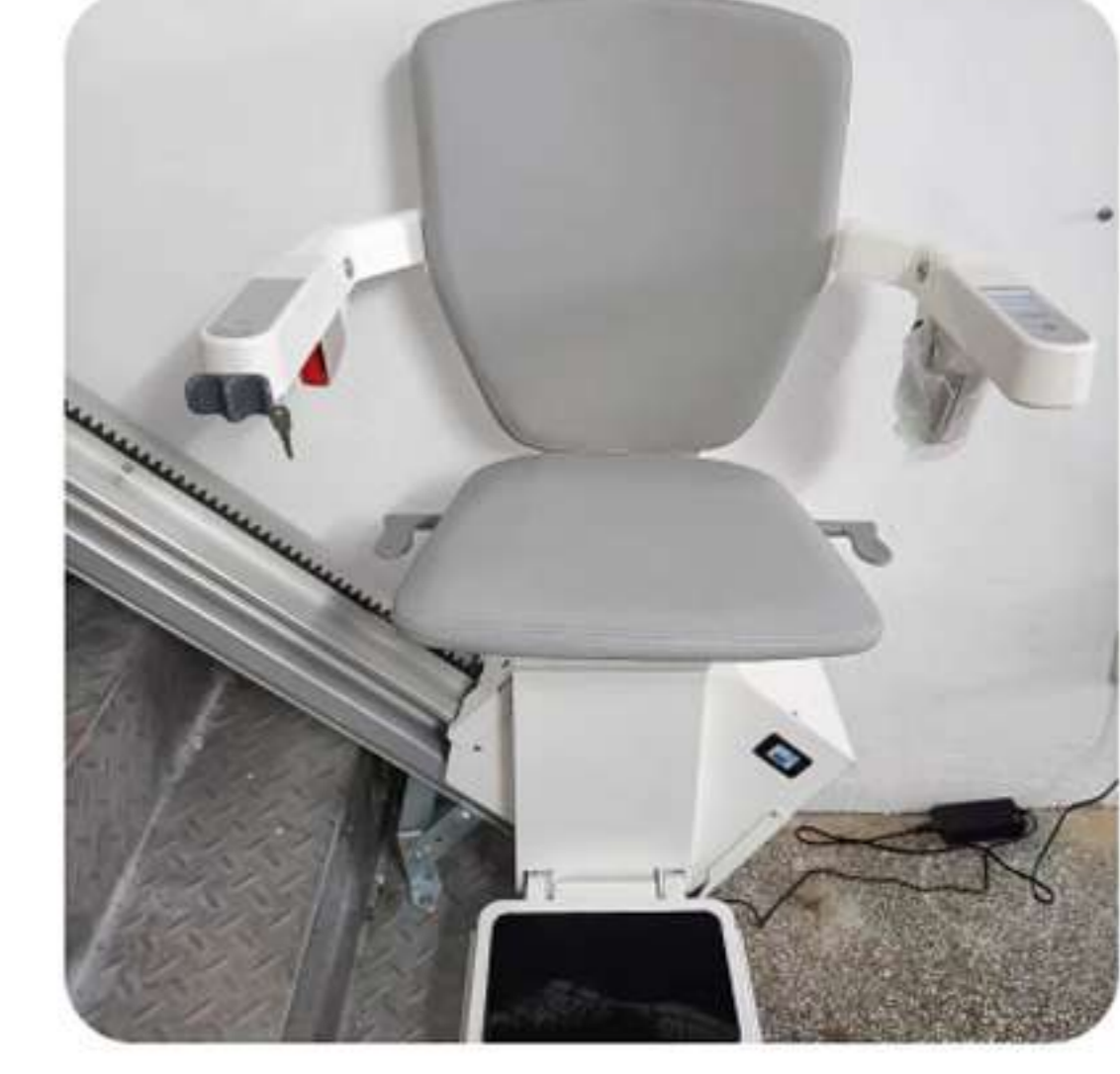

## SEAT UPHOLSTERT OPTIONS

### DURABLE VINYL UPHOLSTERY



### WOVEN SEAT (OPTIONAL, EXTRA COST)



### LEATHER SEAT (OPTIONAL, EXTRA COST)

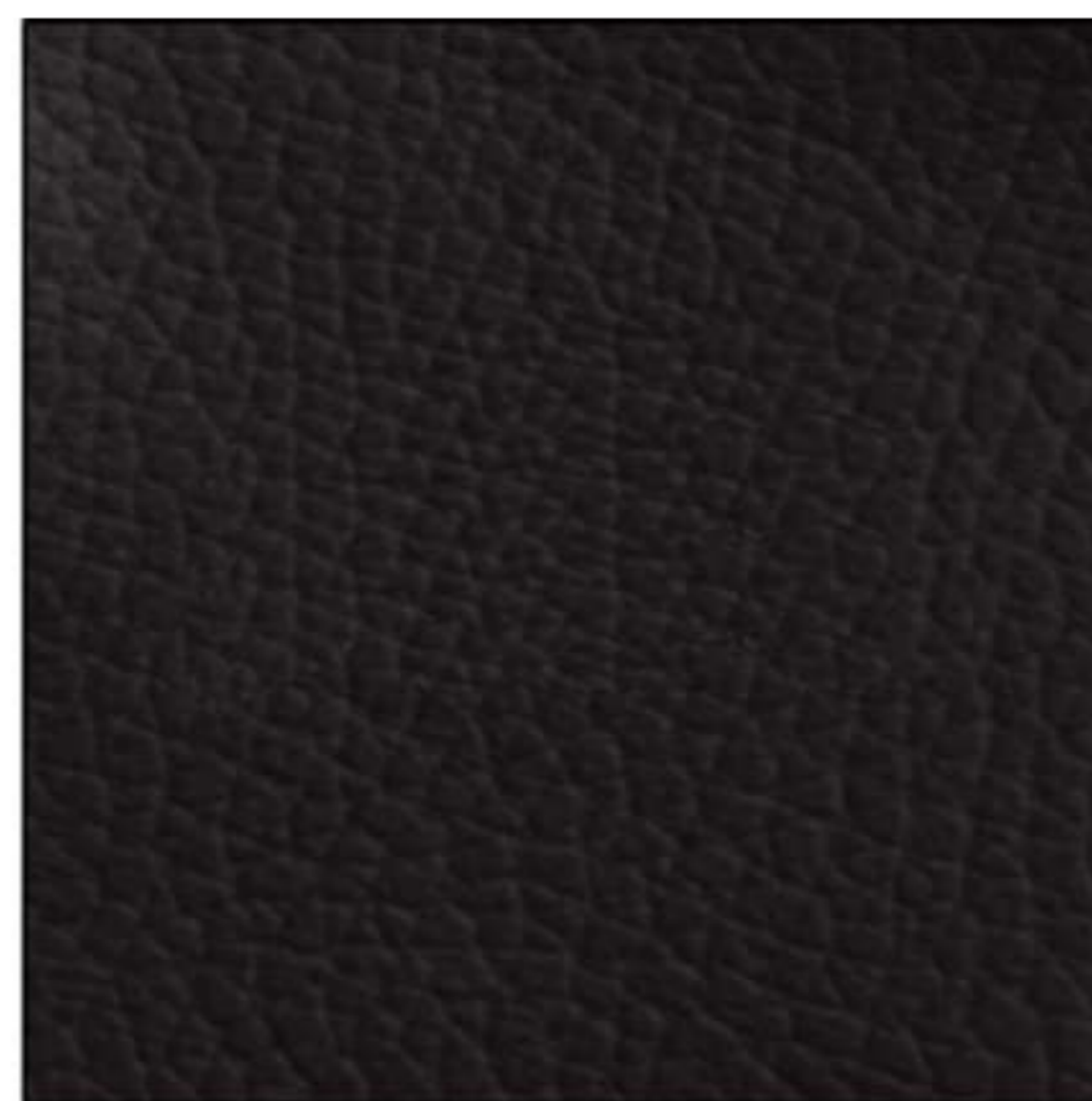

# KEY FEATURES & SAFETY



## Control lever on the armrest

Simply push the lever in the direction you wish the stairlift to move. For safety reasons, please hold the lever down to keep it moving.



## Wireless Call Switch

The elevator is equipped with a wireless remote control, allowing you to call the elevator from upstairs or downstairs.ing.



## Emergency Descent Function

It features an emergency descent button that allows you to descend even if the elevator stops during ascent or descent.



## Retractable Seat Belt

The seat belt features a retractable mechanism, so it won't get in anyone's way.



## Foldable Compact Seat

Folds away when not in use, allowing you to use the stairs more freely.



## Obstacle Detection Function

If the elevator encounters an obstacle, the sensors will detect it and immediately stop operation.



## High-level safety design with emergency descent

if the lift stops, it automatically lowers to a safe exit point. The master switch stops the lift the moment it's released.



## Extendable Armrest

The armrest can be fully opened to facilitate transfers from a wheelchair.



## Simultaneous folding

When the armrests are folded up, the seat and footrest fold simultaneously, saving space when folded.



## Footrest

You may also replace the footrest with a smaller one depending on the staircase configuration. (In some cases, you may only be able to use a smaller footrest when going up or down stairs.)



## Battery-Powered

It utilizes a battery-powered system that can be recharged at designated charging points when parked, ensuring peace of mind during emergencies such as power outages.



## Adjustable landing angle

When the elevator reaches its destination, it automatically rotates to lower the seat to the desired position.

Designed for everyday reliability, all ENGKE stairlifts share the same core safety and comfort features.

These functions ensure smooth operation, stable movement, and confident use for elderly users in both straight and curved installations.

# TECHNICAL SPECIFICATIONS (FOR STRAIGHT & CURVED MODELS)

Item	ENGKE MOVE Essential Essential & Practical	ENGKE MOVE Comfort Best Value	ENGKE MOVE Pro Premium & High Capacity
Rail Type	Straight / Curved	Straight / Curved	Straight / Curved
Market Position	Essential & Practical	<b>Mainstream / Best Value</b>	High Capacity & Premium
Seat Rotation	Manual	Automatic	Automatic
Footrest	Manual	Powered	Powered
Seat Folding	Manual Folding	Automatic Folding	Automatic Folding
Drive System	Quiet & Smooth Drive System		
Power Supply	Battery Powered (Backup Included)	Battery Powered (Backup Included)	Dual Battery System
Remote Control	Single Remote	Dual Remotes	Dual Remotes
Display	●	System Status Display	System Status Display
Voice Prompt	●	●	Multi-language Voice Prompt (Optional)
Seat Material	Standard Durable Seat	Leather Seat (Color Optional)	Premium Leather Seat (Color Optional)
Rail	Heavy-Duty Rail	Heavy-Duty Rail	Heavy-Duty Rail (Custom Color)
Safety Features	Obstacle Detection / Anti-pinch / Seat Belt / Soft Start & Stop		
Load Capacity	130 kg	130 kg	<b>150–160 kg</b>
Rail Length	3–6 m (Customizable)	3–6 m (Customizable)	Project-based Customization
Installation Difficulty	Very Easy	Very Easy	Moderate

## Technical Specifications & Pricing Overview

The specifications listed above apply to both Straight and Curved Stairlift systems. All models are built on the same core platform, featuring identical drive units, safety systems, and functional configurations.

The primary difference lies in the rail design and motion control system. Curved stairlifts require a precision-engineered rail structure combined with an advanced dynamic balancing and speed-control system, ensuring smooth, stable, and safe operation when navigating turns, landings, and changes in direction.

This higher level of engineering complexity results in increased manufacturing precision, system calibration, and installation requirements, which is reflected in the overall pricing structure.

Based on the combination of rail type (Straight or Curved) and configuration level (Essential, Comfort, or Pro), ENGKE Mobility offers a total of six standardized versions, allowing customers to select the most suitable solution for their needs.

## Factory-Direct Advantage

As a direct manufacturer, ENGKE Mobility provides end-to-end solutions — from engineering and production to installation guidance and after-sales support.

By eliminating unnecessary intermediary steps, we ensure clearer technical communication, faster response times, and optimized overall project costs for our partners.

For customized configurations or project-based pricing, please contact our team for professional consultation.

# Accessibility Platform Lift



The Platform Wheelchair Lift is designed to help wheelchair users travel safely and smoothly between different floor levels. It features safe and reliable performance, simple operation, and stable lifting. The lift can be configured with either a sprocket drive or rack-and-pinion drive, allowing customers to choose the most suitable option based on on-site requirements.

This equipment is available in Straight, Curved, and Vertical models, and can be installed both indoors and outdoors to meet various architectural conditions.

Safety guards are equipped on three sides of the platform. When any obstruction or displacement is detected, the lift automatically stops to protect the user.



Straight Vertical Platform Lift



Curved Vertical Platform Lift



Outdoor Vertical Platform Lift

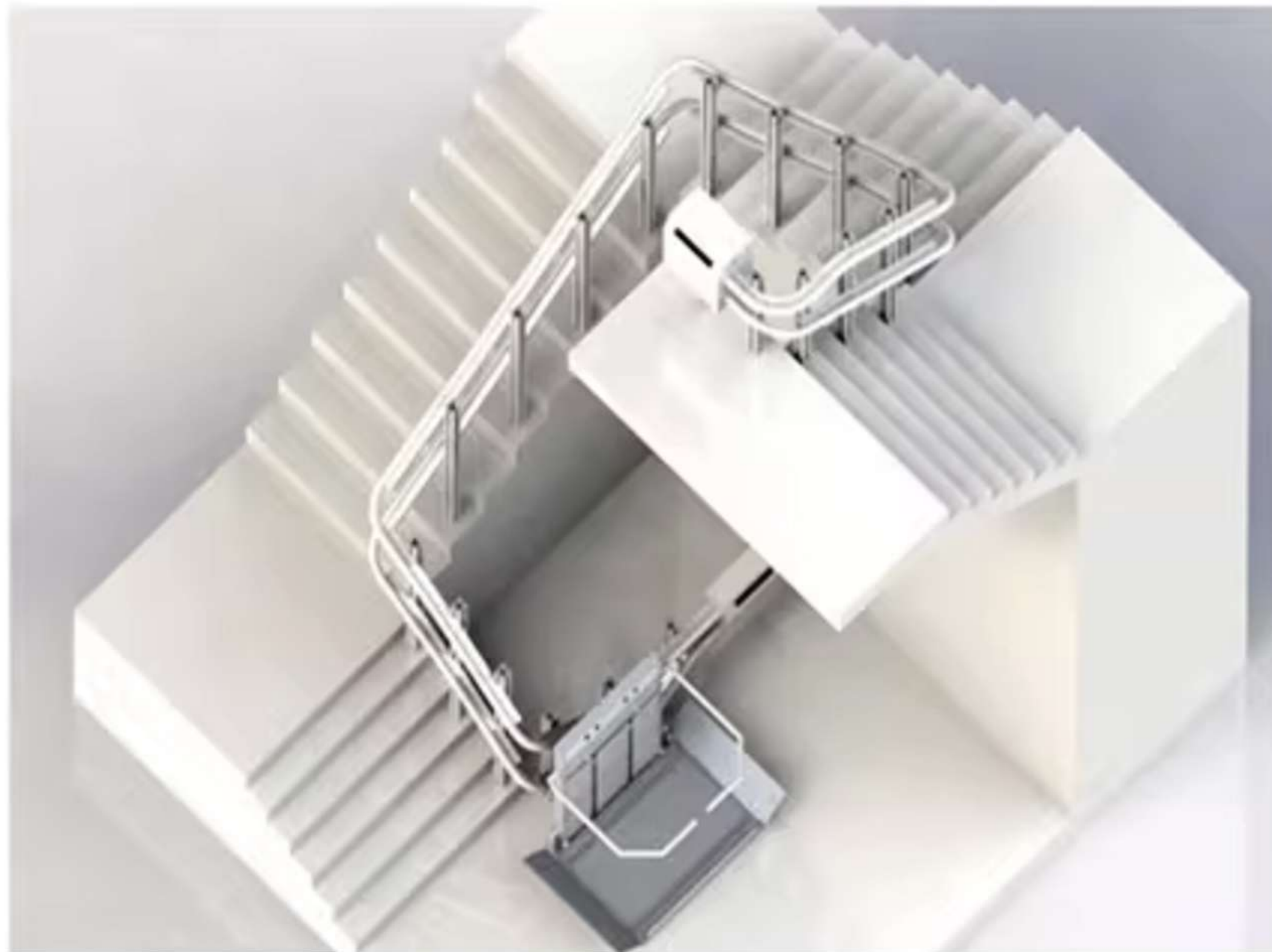
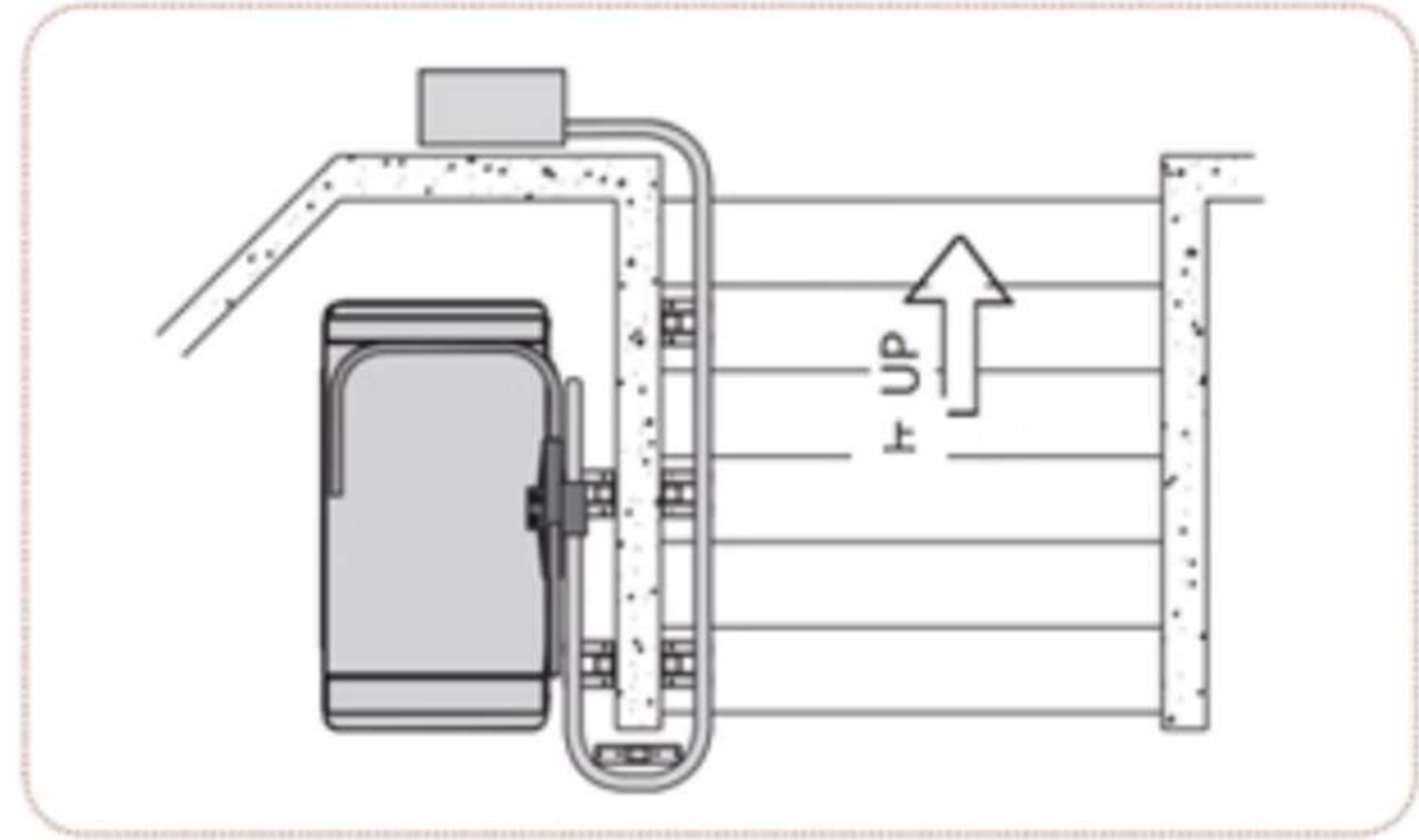
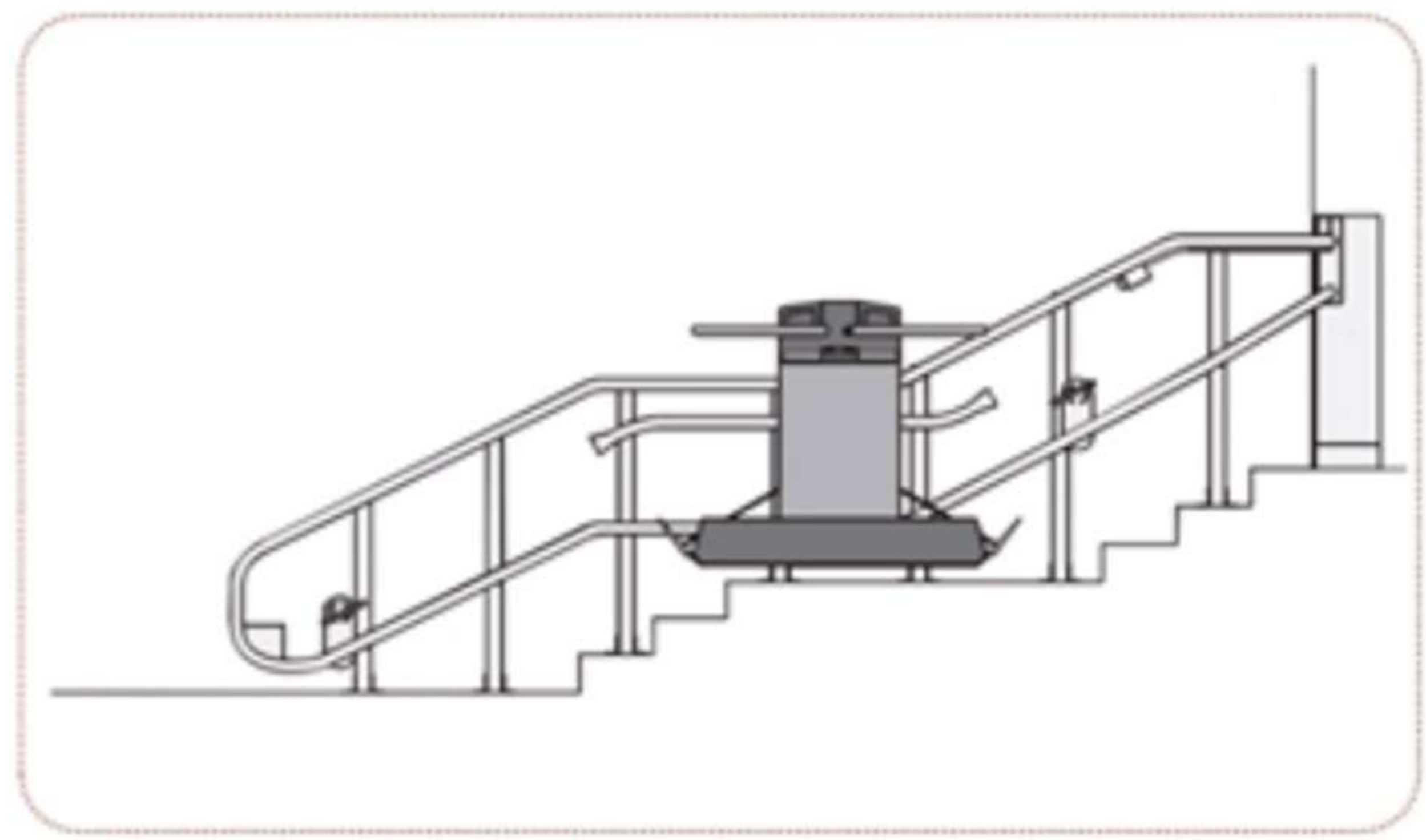
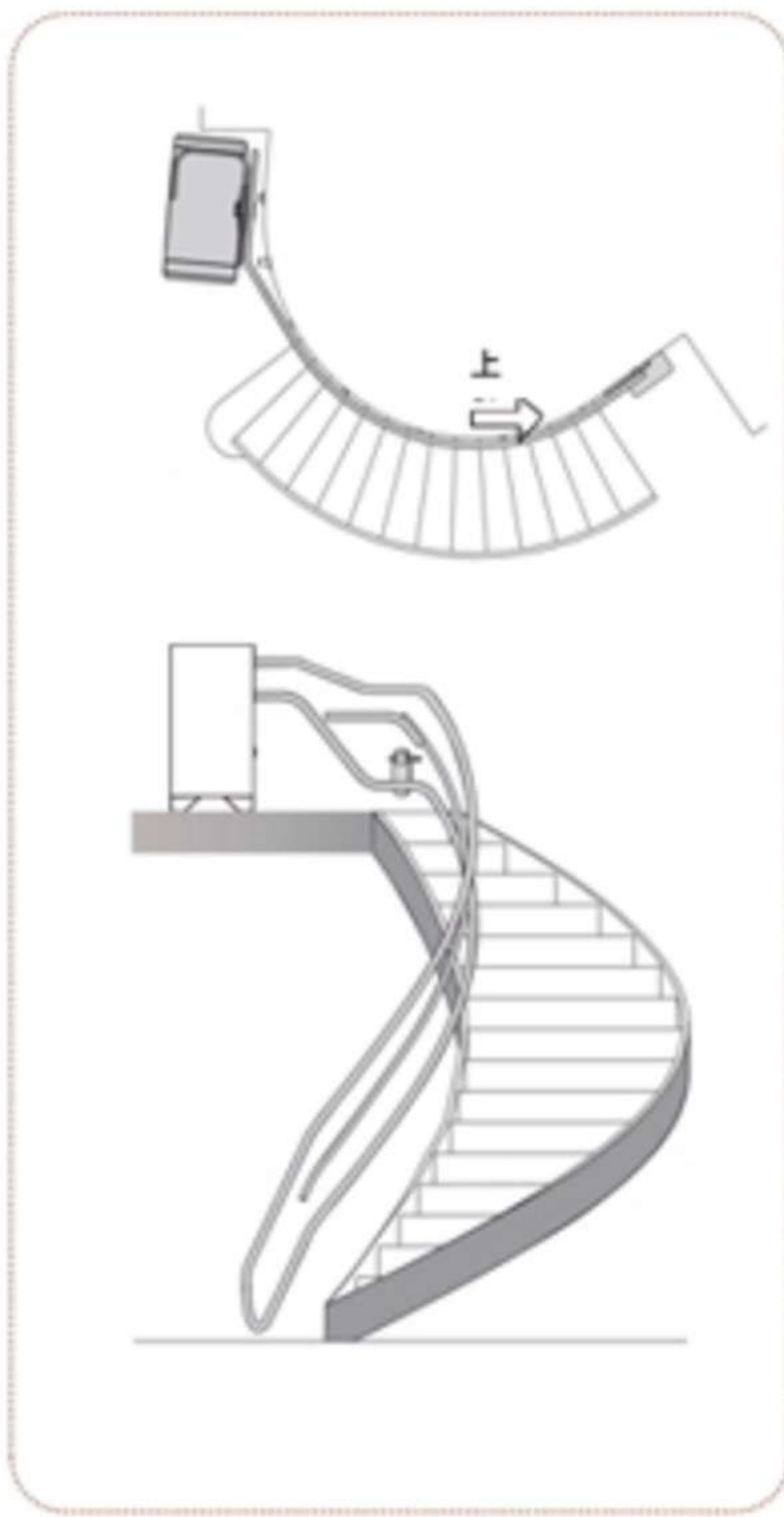

Model	EKSO240
Platform Loading Capacity	240kg
Operating surface size	680mm*60mm (length* height)
Side flip board size	865mm*260mm (Length* width)
The flip angle of the side panel is adjustable	-30°~ +60°
Guardrail height	920mm
Equipment thickness	Host thickness 100mm±3mm
internal voltage	DC 24Vsafe voltage
Self-weight of host	≈150 kg
Platform size	1100mm*800mm (Length*Width)
Operation button height	1088mm
Platform folding thickness	223mm±1mm(Excluding columns)
Key Press Response	<0.2S



**Emergency Stop Button**  
Pressing the emergency stop button during operation causes the equipment to brake immediately.



**Collision Prevention**  
The guardrail detects displacement and automatically pauses the lift for safety.

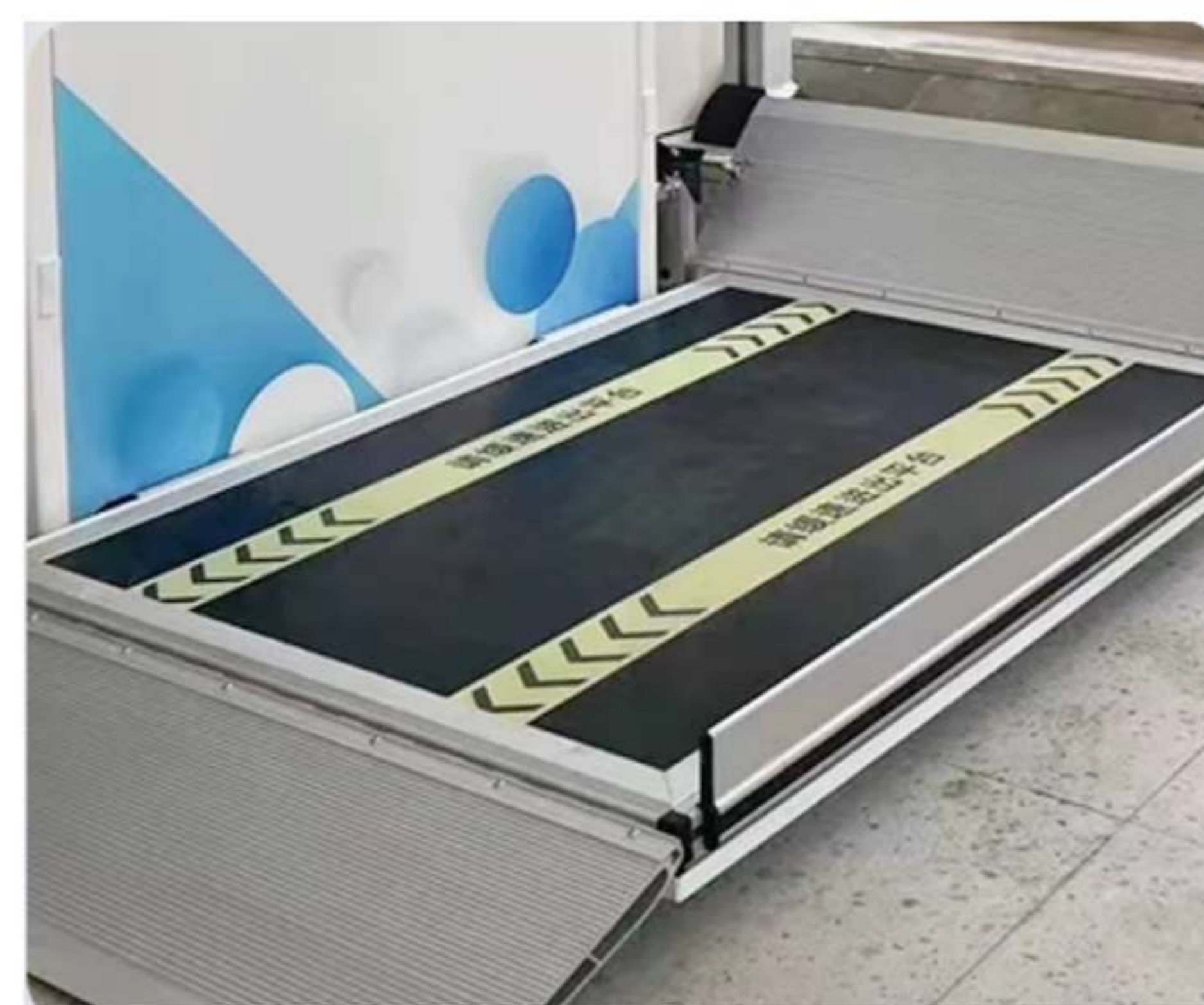

**Anti-slip surface**  
Enhances traction for safer wheelchair access.

## USE CASES

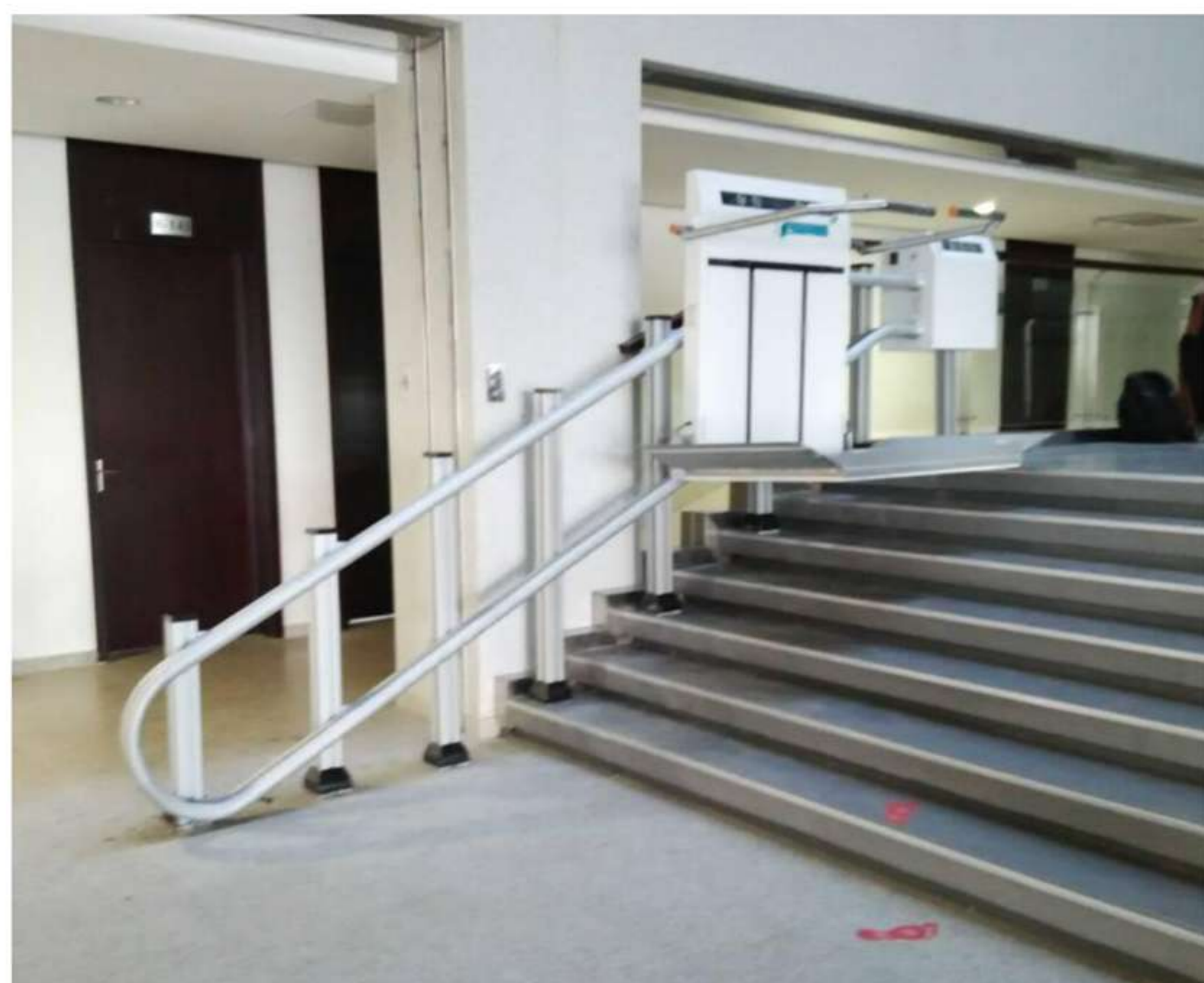



ENGKE.COM



Engke Mobility Group Limited



Whatsapp: 008617727479931  
Email:inquiry@engke.com



Unit 9-20, Area A, Building C,  
Fenda Technology Park Shiyan Subdistrict, Bao'an District,Shenzhen